

CAD FILE:

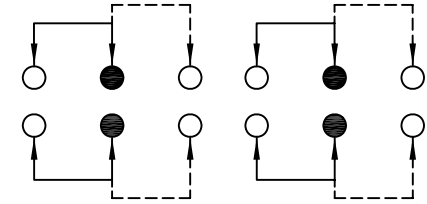

SCHMATIC (SHORTING)

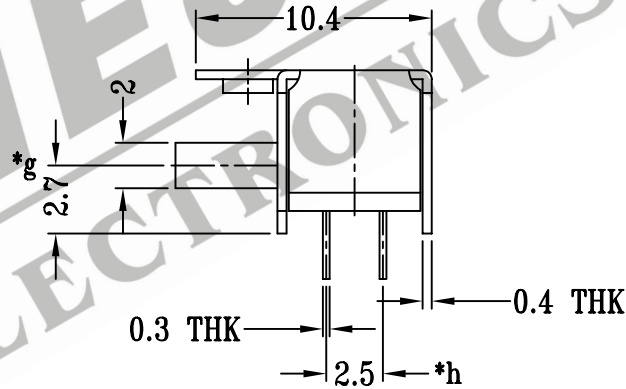
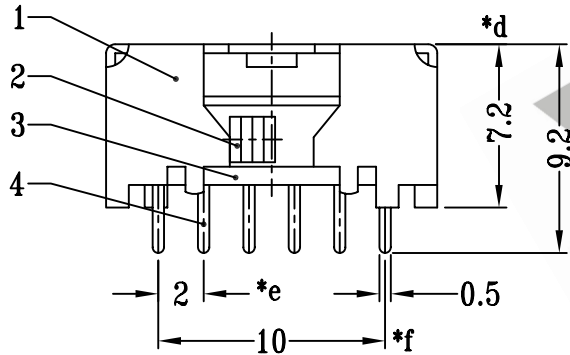
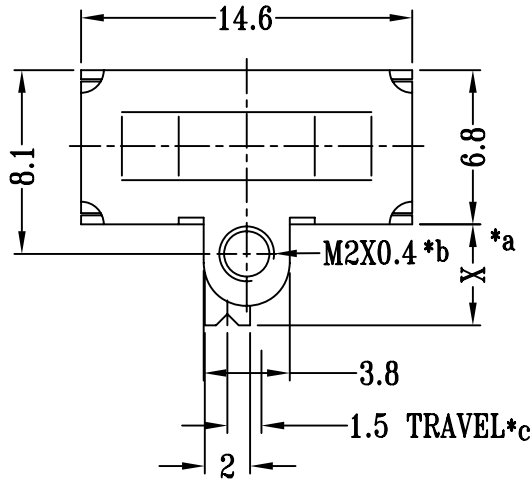
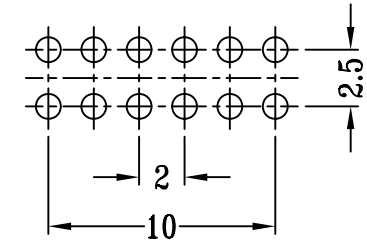

P.C.B LAYOUT

注：“*”表示关键尺寸（8个）

NO.	PARTS	MATERIALS	Q'TY	FINISH	TOLERANCE UNLESS SPECIFIED	SHENZHEN XIEJIA ELECTRONICS CO.,LTD.				
8										
7										
6	SPRING PLATE	STAINLESS STEEL	1	NATURAL	WITHIN: 1.5±0.1mm	ISSUE	DATE	DESCRIPTIONS OF REVISION		APPD.
5	CONTACT CLIP	PBS	4	Ag CLAD	OVER: 1.5±0.2mm					
4	TERMINAL	BRASS STRIP	12	Ag PLATED OVER Ni PLATED	TITLE : HORIZONTAL SLIDE SWITCH	UNIT : mm	DRWG NO.: XJ-DR-SK42C19-00			
3	BASE	PHENOLIC RESIN	1	NATURAL	MODEL: SK-42C19	SCALE: 3:1	DWN.	ZHOUYU	2005-9-28	
2	KNOB	POM	1	BLACK			CHK'D	FANGYING	2005-9-28	
1	FRAME	STEEL STRIP	1	Ni PLATED	ALL MATERIALS MUST BE COMPLIANT TO ROHS	APPD.	KANGXINAN	2005-9-28		